

UDC

中华人民共和国国家标准



P

GB 50243—2002

**Code of acceptance for construction quality of
ventilation and air conditioning works**

2002—03—15 发布

2002—04—01 实施

中华人民共和国国家质量监督检验检疫总局
中华人民共和国建设部

联合发布

Code of acceptance for construction quality of
ventilation and air conditioning works

GB 50243-2002

:

:

: 2002 4 1

2002

[2002]60

<
> ([2001]87)

GB 50243—2002 2002 4 1
 4.2.3 4.2.4 5.2.4 5.2.7 6.2.1 6.2.2 6.2.3 7.2.2 7.2.7 7.2.8 8.2.6
 8.2.7 11.2.1 11.2.4
 GBJ304—88 GB50243—97

中华人民共和国建设部

[2001]87 “

”

GBJ304—88

GB 50243—97

GB

50243—97

”

”

:

1

2

3

4

5

GB 50300—2001

6

7

(

390

:200080 E-mail:kj@chinasiec.com)

:

:

:

:

1	8
2	9
3	11
4	13
4.1	13
4.2	14
4.3	20
5	28
5.1	28
5.2	28
5.3	29
6	32
6.1	32
6.2	32
6.3	34
7	38
7.1	38
7.2	38
7.3	40
8	46
8.1	46
8.2	46
8.3	48
9	51
9.1	51
9.2	51
9.3	54
10	60
10.1	60

10.2	60
10.3	61
11	64
11.1	64
11.2	64
11.3	66
12	68
13	70
A	72
A.1	72
A.2	72
A.3	77
B	79
B.1	79
B.2	79
B.3	79
B.4	80
B.5	83
B.6	84
B.7	84
B.8	85
C	86
C.1	86
C.2	86
C.3	86
C.4	()	86
	128

1

1.0.1

1.0.2

1.0.3

2001

1.0.4

1.0.5

GB 50300—

2

- 2.0.1 air duct
- 2.0.2 air channel
- 2.0.3 ventilation works
- 2.0.4 air conditioning works
- 2.0.5 duct fittings
- 2.0.6 duct accessory
- 2.0.7 seam
- 2.0.8 air leakage rate
- 2.0.9 air system permissible leakage rate
- 2.0.10 air system leakage ratio
- 2.0.11 air cleaning system
- 2.0.12 air leak check with lighting
- 2.0.13 packaged refrigerating unit

- 2.0.14** assembling refrigerating unit
- 2.0.15** design working pressure
- 2.0.16** air cleanliness class
- 2.0.17** corner pieces
- 2.0.18** (FFU FMU) fan filter(module)unit
- 2.0.19** as-built
- 2.0.20** at-rest
- 2.0.21** operational
- 2.0.22** nonmetallic duct
- 2.0.23** foil-insulant composite duct
- 2.0.24** refractory duct

3.0.9

3.0.10

3.0.11

3.0.12

3.0.13

3.0.14

3.0.15 ()

B B.4

(C_n) B B.4.6-1

3.0.16 :

1

2

3

80%

4

4.1

4.1.1

4.1.2

4.1.3

4.1.4

4.1.4-1 4.1.4-2

表 4.1.4-1 圆形风管规格 (mm)

<i>D</i>			
	80	250	240
100	90	280	260
120	110	320	300
140	130	360	340
160	150	400	380
180	170	450	420
200	190	500	480
220	210	560	530
630	600	1250	1180
700	670	1400	1320
800	750	1600	1500
900	850	1800	1700
1000	950	2000	1900
1120	1060		

表 4.1.4-2 矩形风管规格 (mm)

120	320	800	2000	4000
160	400	1000	2500	—
200	500	1250	3000	—
250	630	1600	3500	—

4.1.5

4.1.5

表 4.1.5 风管系统类别划分

	$P(\text{Pa})$	
	$P < 500$	
	$500 < P < 1500$	
	$P > 1500$	

4.1.6

4.1.7

4.2

4.2.1

4.2.1-1

4.2.1-2

4.2.1-3

表 4.2.1-1 钢板风管板材厚度 (mm)

D b				
$D(b) < 320$	0.5	0.5	0.75	1.5
$320 < D(b) < 450$	0.6	0.6	0.75	1.5
$450 < D(b) < 630$	0.75	0.6	0.75	2.0
$630 < D(b) < 1000$	0.75	0.75	1.0	2.0
$1000 < D(b) < 1250$	1.0	1.0	1.0	2.0
$1250 < D(b) < 2000$	1.2	1.0	1.2	
$2000 < D(b) < 4000$		1.2		
1	10		15	
2				
3				
4				

表 4.2.1-2 高、中、低压系统不锈钢板风管板材厚度 (mm)

<i>b</i>	
<i>b</i> 500	0.5
500 <i>b</i> 1120	0.75
1120 <i>b</i> 2000	1.0
2000 <i>b</i> 4000	1.2

表 4.2.1-3 中、低压系统铝板风管板材厚度 (mm)

<i>b</i>	
<i>b</i> 320	1.0
320 <i>b</i> 630	1.5
630 <i>b</i> 2000	2.0
2000 <i>b</i> 4000	

: 10% 5
:

4.2.2

4.2.2-1 4.2.2-2 4.2.2-3
4.2.2-4
4.2.2-5

表 4.2.2-1 中、低压系统硬聚氯乙烯圆形风管板材厚度 (mm)

D	
D 320	3.0
320 D 630	4.0
630 D 1000	5.0
1000 D 2000	6.0

表 4.2.2-2 中、低压系统硬聚氯乙烯矩形风管板材厚度 (mm)

<i>b</i>	
<i>b</i> 320	3.0
320 <i>b</i> 500	4.0
500 <i>b</i> 800	5.0
800 <i>b</i> 1250	6.0
1250 <i>b</i> 2000	8.0

表 4.2.2-3 中、低压系统有机玻璃钢风管板材厚度 (mm)

D	b	
D(b) 200		2.5
200 D(b) 400		3.2
400 D(b) 630		4.0
630 D(b) 1000		4.8
1000 D(b) 2000		6.2

表 4.2.2-4 中、低压系统无机玻璃钢风管板材厚度 (mm)

D	b		
D(b) 300		2.5	3.5
300 D(b) 500		3.5	4.5
500 D(b) 1000		4.5	5.5
1000 D(b) 1500		5.5	6.5
1500 D(b) 2000		6.5	7.5
D(b) 2000		7.5	8.5

表 4.2.2-5 中、低压系统无机玻璃钢风管玻璃纤维布厚度与层数 (mm)

D b				
	0.3	0.4	0.3	0.4
D(b) 300	5	4	8	7
300 D(b) 500	7	5	10	8
500 D(b) 1000	8	6	13	9
1000 D(b) 1500	9	7	14	10
1500 D(b) 2000	12	8	16	14
D(b) 2000	14	9	20	16

: 10% 5
:

4.2.3

: **10%** **5**
:

4.2.4

B1

: **10%** **5**
:

4.2.5

1.5

$Q_L = 0.1056P^{0.65}$
 $Q_M = 0.0352P^{0.65}$
 $Q_H = 0.0117P^{0.65}$

Q_L Q_M Q_H —
 [m³/(h· m²)]
 P — (Pa)

50%

1.5

1 5

3 15m²

(

A)

4.2.6

1

2 4.2.6-1 4.2.6-2

150mm 100mm

表 4.2.6-1 金属圆形风管法兰及螺栓规格(mm)

D			
D 140	20× 4	—	M6
140 D 280	25× 4	—	
280 D 630	—	25× 3	M8
630 D 1250	—	30× 4	
1250 D 2000	—	40× 4	

表 4.2.6-2 金属矩形风管法兰及螺栓规格(mm)

b	()	
b 630	25× 3	M6
630 b 1500	30× 3	M8
1500 b 2500	40× 4	
2500 b 4000	50× 5	M10

: 5% 5

:

4.2.7 () :

1 4.2.7-1 4.2.7-2 4.2.7-3

120mm

表 4.2.7-1 硬聚氯乙烯圆形风管法兰规格 (mm)

D	(×)		D	(×)	
---	-------	--	---	-------	--

: 5% 5

:

4.2.9

:

:

4.2.10

:

1 () 800mm

1250mm 4m²

2 630mm 800mm 1250mm

1.2m² 1.0m²

3

: 5% 5

:

4.2.11

4.2.10

:

1 500mm

450mm

2

: 5% 5

:

4.2.12

500mm

: 20% 2

:

4.2.13

:

1 900mm 900mm

2

3

S

4

1 5

5

6

: 20% 5
:

4.3

4.3.1

1 () 4.3.1-1

3°

表 4.3.1-1 圆形弯管曲率半径和最少节数

D(mm)	R										
		90°		60°		45°		30°			
80 220	1.5D	2	2	1	2	1	2	—	2		
220 450	D 1.5D	3	2	2	2	1	2	—	2		
450 800	D 1.5D	4	2	2	2	1	2	1	2		
800 1400	D	5	2	3	2	2	2	1	2		
1400 2000	D	8	2	5	2	3	2	2	2		

2

10mm

3

: 300mm 2mm

300mm 3mm 2mm

3mm 2mm

4

: 10% 5

20% 5

:

4.3.2

1

2mm

2

6mm

3

5mm
100mm

4

4.2.6-1 4.2.6-2

: 10% 5

20% 5

:

4.3.3

1 4.3.3-1 4.3.3-2

2 4.3.3-3

() 5/1000

3 c S 2mm 630mm

2mm

20mm

4

5/1000 150mm

表 4.3.3-1

圆形风管无法兰连接形式





		(mm)		
		—	30mm	700mm
		—	20mm	
		—	20mm	
			20mm	
				
				100mm

表 4.3.3-2 矩形风管无法兰连接形式



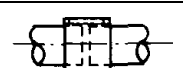

		(mm)	
S		0.7	
C		0.7	
		0.7	
		0.7	
		0.7	
		1.0	
		1.0	
		0.7	
		0.8	

表 4.3.3-3 圆形风管的芯管连接

D(mm)	l(mm)	()	(mm)	
120	120	3× 2	-1 0	-3 -4
300	160	4× 2		
400	200	4× 2	-2 0	-4 -5
700	200	6× 2		
900	200	8× 2		
1000	200	8× 2		

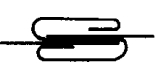

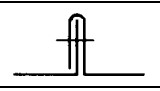
5 : 10% 5 20%
 4.3.4 :

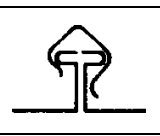
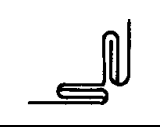
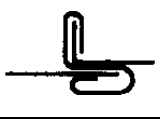
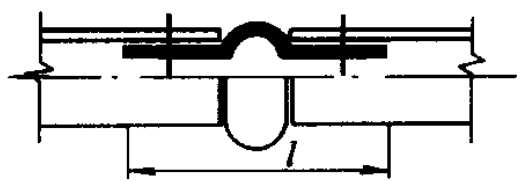
4.3.4

1

()

4.3.4



图 4.3.4 风管的加固形式

2

3

220mm

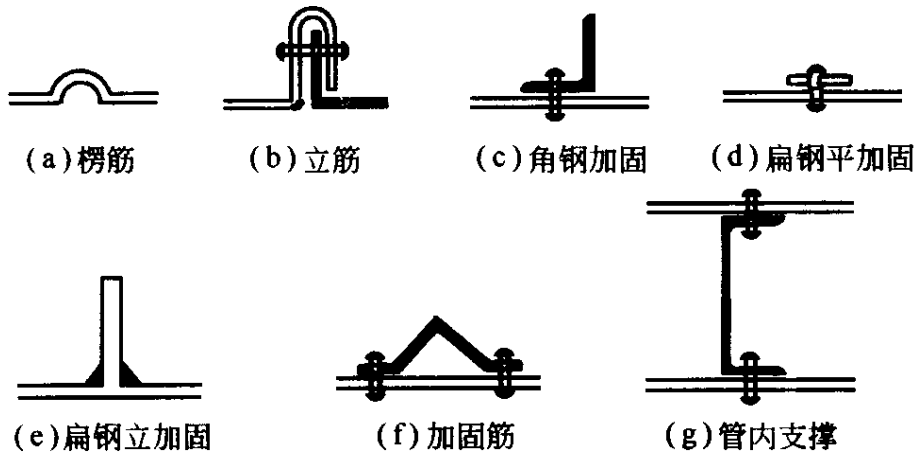
4

950mm

5

1250mm

: 10% 20% 5

:

4.3.5

4.3.1 1 3 4.3.2 1

:

1



2mm

5mm

2

4.3.5

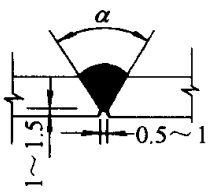
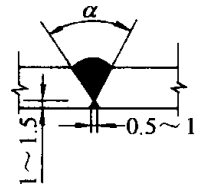
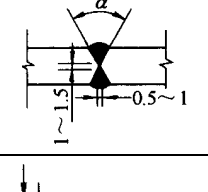
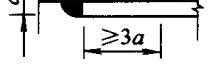
表 4.3.5 焊缝形式及坡口

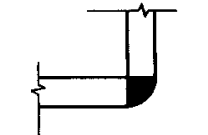
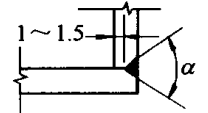
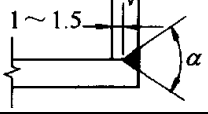
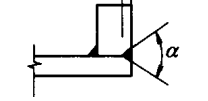
			(mm)	(mm)	a (°)
			2 3	3 5	70 90
			2 3	5 8	70 90
			2 3	8	70 90
				3 10	—
				6 18	—
				3	—
				3 5	70 90
				5 8	70 90
				6 15	70 90

3

4

4.3.11

:

10%

5%

5

:

4.3.6 4.3.1 1 3 4.3.2 1

1

2

5mm

3mm

5mm

3

3mm

2mm

4

900mm

1250mm

:

10%

5%

5

:

4.3.7 4.3.1 1 3 4.3.2 1

1

2

4.3.7

3

:

10%

5%

5

:

表 4.3.7 无机玻璃钢风管外形尺寸(mm)

300	3	3	2	3
301 500	3	4	2	3
501 1000	4	5	2	4
1001 1500	4	6	3	5
1501 2000	5	7	3	5
2000	6	8	3	5

4.3.8

:

10%

:

4.3.9 4.3.1 2 3 4.3.2 2

:

1						5mm
2						
3						2mm
4						
	:	10%	5%	5		
	:					
4.3.10			4.3.1	2 3	4.3.2	2
	:					
1						
2						
			25mm			
3						
4						
	:	10%	5			
	:					
4.3.11						
1						
2				1 5		65mm
6 9		100mm				
3						
4						
	:	20%	10%	5		
	:					

5

5.1

5.1.1

5.1.2

5.2

5.2.1

: 10% 1
:

5.2.2

: 10% 1
:

5.2.3

()

: 10% 2
:

5.2.4

:
:

5.2.5

()

: 10% 1
:

5.2.6

1000Pa (1.5

) ()

: 10% 1

5.2.7 :

5.2.8 :

800mm

:

5.3

5.3.1 :

1

2

2mm

3

1.2m²

: 10% 1

:

5.3.2 :

1

2

3

4

: 10% 1

:

5.3.3 :

1

2

3

: 10% 1

:

5.3.4 :

1

2

3
 :

	10%	1
--	-----	---

:

5.3.5
 :

	10%	1
--	-----	---

:

5.3.6 :

1

2

3

:	10%	1
---	-----	---

:

5.3.7 :

1

2

3

4

2%

5

3° 4°

:	10%	1
---	-----	---

:

5.3.8

1250mm

:	10%	1
---	-----	---

:

5.3.9

:

1

2 150 300mm
 3
 4 100mm
 : 10% 1
 :

5.3.10 :
 1
 2 4.2.5
 3
 4
 : 10% 1
 :

5.3.11
 : 20% 1
 :

5.3.12
 5.3.12
 : 5% 1
 :

表 5.3.12 风口尺寸允许偏差(mm)

	250	250	
	0 -2	0 -3	
	300	300 800	800
	0 -1	0 -2	0 -3
	300	300 500	500
	1	2	3

6

6.1

6.1.1

6.1.2

6.1.3

6.2

6.2.1

1.6mm

: 20% 1
:

6.2.2

:

1

2

3

: 20% 1
:

6.2.3

80

: 20% 1
:

6.2.4

:

1

2

3
 : 20% 5
 :
 6.2.5 ()
 200mm
 : 20% 5
 :
 6.2.6 :
 1
 2 5
 8mm
 3
 : 20% 1
 :
 6.2.7 :
 1 4
 2 45°
 : 20% 2
 :
 6.2.8
 4.2.5 :
 1 5% 1
 20% 1

2 1 5

6 9 4.2.5

:

:

A

6.2.9

:

:

6.3

6.3.1

:

1

2

3

4

3mm

5

6

2m

7

8

:

10%

1

:

6.3.2

:

1

2

3

150mm

4

:

10%

1

6.3.3 : 3/1000
 20mm 2/1000
 20mm 45°

10% 1
 6.3.4 :
 1 400mm 4m
 400mm 3m 5m 3.75m
 3m
 2 4m 2
 3
 4 2500mm
 5 200mm
 6 20m
 7 1

10% 1
 6.3.5 :
 1
 2

3 20m

4 3m

: 10% 1

:

6.3.6 :

1

5mm

2

3

: 10% 1

:

6.3.7 :

1

5/1000

2

: 20% 5

:

6.3.8

630mm

() ()

: 10% 5

:

6.3.9

: 10% 5

:

6.3.10

: 10% 5

:

6.3.11

				10mm	
			3/1000		
			2/1000		
	:	10%	1	5	2
	:				
6.3.12	:				
1					
2					
	:	20%	1	5	2
	:				

7

7.1

7.1.1 5kPa

7.1.2

7.1.3

7.1.4

7.1.5

7.2

7.2.1 :

1

2

3

:

:

7.2.2 ()

:

:

7.2.3 :

1

2

GB/T14294

:

20%

1

1 5

6 9

50%

:

7.2.4

:

1

2

7.2.9

:

7.2.10

:

7.3

7.3.1

:

1

7.3.1

1/100

表 7.3.1 通风机安装的允许偏差

1			10mm	
2			± 10mm	
3			1mm	
4			0.2/1000 0.3/1000	0° 180°
5			0.05mm	
			0.2/1000	

2

1/1000

3

2mm

4

:

20%

1

7.3.2

:

1

2

3

4

()

: 20% 1

:

7.3.3

:

1

2

3

4

5

: 20% 1

:

7.3.4

:

1

2

3

: 20% 1

:

7.3.5

:

1

7.3.5

表 7.3.5 除尘器安装允许偏差和检验方法

		(mm)	
1		10	
2		± 10	
3		2	
		10	

2

3

: 20% 1

:

7.3.6

:

1

5mm

10mm

2

5mm

10mm

3

15mm

10mm

4

7m

5mm

7m

10mm

5

0.7

: 20% 1

:

7.3.7

:

1

2

25 35N/m

3

4

2mm

: 20% 1

:

7.3.8

:

1

2				2/1000
3				
	:	20%	1	
	:			
7.3.9			:	
1		()	
2				1/1000
3				
				2/1000
				2/1000
4				
	:	20%	5	
	:			
7.3.10			:	
1				
2			1/1000	± 1mm
3				
	:	20%	5	
	:			
7.3.11		(FFU FMU)		:
1				7.2.5
			FFU FMU	
2		FFU		
	:	20%	2	
	:			
7.3.12			:	
1				6 8mm

25% 50%

2

2/3

50

:

20%

5

:

7.3.13

:

1

2

3

4

:

10%

5

:

7.3.14

:

1

2

3

:

10%

1

:

7.3.15

:

1

1.5

2min

2

3

:

10%

1

:

7.3.16

: 20% 1
 :
7.3.17

: 20% 1
 :
7.3.18

:
 :
7.3.19

2/1000
 : 10% 1
 :

7.3.20
 : 10% 1
 :

8

8.1

8.1.1 () 2.5MPa -20 150

8.1.2

8.1.3

8.1.4 7.1.5

8.1.5

GB 50274

8.2

8.2.1 :

1

2

3

:

:

8.2.2

:

:

8.2.3

8.2.4

8.2.5

1

2

3

)

2

4

200mm

8.2.5

表 8.2.5 制冷剂管道坡度、坡向

()		10/1000
()		3/1000
		10/1000
		(1 3)/1000
		(3 5)/1000

5

:

20%

5

5

:

8.2.6

8.2.7 :
 :
 0.005MPa

8.2.8 :
 :
 (10%)

8.2.9 :
 :
 20% 5

8.2.10 :
 :

8.3

8.3.1 :
 1 8.3.1

表 8.3.1 制冷设备与制冷附属设备安装允许偏差和检验方法

		(mm)	
1		10	
2		± 10	

2 1/1000

3 1/1000

4				
			2mm	
5				
	:			
	:			
8.3.2				
	:			
	:			
8.3.3				
1/1000		0.2/1000		0.05mm
	:			
	:			
8.3.4			:	
1				
	20mm			
2			3.5D()	
	0.08D			
3			90°	
	1.5D			
4				1%
5			8.3.4	
		0.1		1mm

表 8.3.4 承插式焊接的铜管承口的扩口深度表(mm)

	DN15	DN20	DN25	DN32	DN40	DN50	DN65
	9 12	12 15	15 18	17 20	21 24	24 26	26 30

6

9

: 20% 5
:

8.3.5

:

1

1.5

5min

1.1

30s

2

3

4

5

: 20% 5
:

8.3.6

0.6MPa

5min

:
:

9

9.1

9.1.1

()

()

9.1.2

DN100

9.1.3

9.1.4

GB50242—2002

9.2

9.2.1

: 10% 5
:

9.2.2

:

1

3.0.11

2

3

4

(:)

) 2h

5

20 50mm

: 10% 5
:

9.2.3

1 : 1.0MPa 1.5
0.6MPa 1.0MPa
0.5MPa
2 ()
: 10min 60min
:
10min 0.02MPa
3 1.5 1.15
4
:
:

9.2.4

1 :
2
3
GB 12220 1.0MPa
1.5 5min
1.1
9.2.4

表 9.2.4 阀门压力持续时间

DN(mm)	(s)	
50	15	15
65 200	30	15
250 450	60	30
500	120	60

) :1 2 5% 1 ()
20% 1

9.2.5

()
()
: 20% 1
:

9.2.6

:

9.2.7

2h

:
:

9.2.8

:
:

9.3

9.3.1 (PVC-U) (PP-R)
 (PB) (PEX)

: 20% 2
 :

9.3.2 :
 1

9.3.2 1/100 10mm

50mm

表 9.3.2 管道焊接坡口形式和尺寸

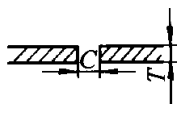
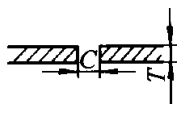
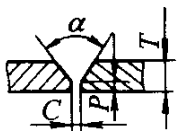
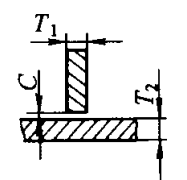
	T(mm)						
				C(mm)	P(mm)	$\alpha(^{\circ})$	
1	1 3	I		0 1.5	—	—	0.1T, 2mm 3mm
	3 6			1 2.5			
2	6 9	V		0 2.0	0 2	65 75	
	9 26			0 3.0	0 3	55 65	
3	2 30	T		0 2.0	—	—	

2

GB 50236 11.3.3

()
 : 20% 1
 :

9.3.3 10%

2 3

: 5% 5

9.3.4 :
 1.5/1000 2mm
 : 5% 5
 :
 9.3.5 :
 1
 2 3.5
 4 1.5 1
 8/100 15%
 3
 8‰ 150mm
 4 ()
 5 9.3.5

表 9.3.5 管道安装的允许偏差和检验方法

		(mm)	
			25
			15
		60	
			± 20
			± 15
		± 25	
	DN 100mm	2L‰	40
	DN 100mm	3L‰	60
		5L‰	25
			15
			3
L——		(mm)	

: 10% 5
:

9.3.6 1.0MPa ()

9.3.6-1

1.0 2.5MPa ()
()

9.3.6-2

表 9.3.6-1 钢塑复合管螺纹连接深度及紧固扭矩

(mm)	15	20	25	32	40	50	65	80	100
(mm)	11	13	15	17	18	20	23	27	33
	6.0	6.5	7.0	7.5	8.0	9.0	10.0	11.5	13.5
(N·m)	40	60	100	120	150	200	250	300	400

表 9.3.6-2 沟槽式连接管道的沟槽及支、吊架的间距

(mm)	(mm)	(mm)	(m)	(mm)
65 100	2.20	0 +0.3	3.5	1.0
125 150	2.20	0 +0.3	4.2	1.5
200	2.50	0 +0.3	4.2	
225 250	2.50	0 +0.3	5.0	
300	3.0	0 +0.5	5.0	
1				
2				

: 10% 5
:

9.3.7 ()

) 1.5

: 10% 5
:

9.3.8

:

1

2 ()

15m

3

()

4

1/2

5

2 3

9.3.8

表 9.3.8 钢管道支、吊架的最大间距

(mm)	15	20	25	32	40	50	70	80	100	125	150	200	250	300	
(m)	L1	1.5	2.0	2.5	2.5	3.0	3.5	4.0	5.0	5.0	5.5	6.5	7.5	8.5	9.5
	L2	2.5	3.0	3.5	4.0	4.5	5.0	6.0	6.5	6.5	7.5	7.5	9.0	9.5	10.5
	300mm							300mm							
1	2.0MPa							200kg/m ³							
2	L ₁	L ₂													

6

0.1

: 5% 5

:

9.3.9

(PVC-U)

(PP-R)

(PEX)

: 5% 5

:

9.3.10

()

:

1

3mm

2

3 ()

4

: 10% 2
:

9.3.11

:

1 ± 20mm

2

2/1000

30mm

3

4

:
:

9.3.12

:

1 ± 10mm

2

3

3

0.1/1000

0.20/1000

0.05/1000

0.2/1000

0.05mm

4

9.3.13

15mm

± 5mm

1/1000

:
:

:
:

10

10.1

10.1.1

10.1.2

10.1.3

10.1.4

10.1.5

10.2

10.2.1

: 1

:

10.2.2

:

:

10.2.3

:

1 800mm

2 2m

:

:

10.2.4

()

: 10% 5

:

10.2.5

(

)

:

:

10.3

10.3.1

: 10%

:

10.3.2

: 10% 2

:

10.3.3

: 10% 2

:

10.3.4

5mm 10mm ()

: 10% 10% 2

:

10.3.5

:

1

2

3

4

: 10%

:

10.3.6

:

1

2

16

	10	8	
	120mm		
	3		0.8
	4		
	50mm		
	:	10%	5
	:		
10.3.7			
	:	10%	
	:		
10.3.8			30 50mm
	:	10%	10m ²
	:		
10.3.9			
	:	10%	5
	:		
10.3.10			:
1			
2			5mm
2mm			
	100mm		
3			300 350mm
	2		
4			
	:	10%	10
	:		
10.3.11			:
1			

2

3

30 50mm

: 10% 10m

:

10.3.12

:

1

20 25mm

2

: 10%

:

10.3.13

: 10%

:

11

11.1

11.1.1

11.1.2

11.1.3

11.1.4

()

8h

()

2h

11.1.5

()

24h

3

11.2

11.2.1

()

:

1

2

:

:

11.2.2

:

1

2h

70

80

2

2h

70

75

3

1

2h

4

GB 50274

8h

5

()

: 1

10%

1

2 3 4

5

20%

5

:

11.2.3

:

1

10%

2

10%

3

:

10%

1

:

11.2.4

()

:

10%

2

:

11.2.5

:

1

0 20%

15%

10%

2

0 20%

0.25

10%

3

5Pa

10Pa

4

5

0.6m

:
:

5%

1

B

11.3

11.3.1

:

1

60mL/h

5mL/h

2

3

: 1 2 20% 1 3 10%

5

:

11.3.2

:

1

2

15%

3

11.3.3

:

1

20%

2

(BA

FA)

3

4				
5				0
25Pa				
6		— —	GB 9068	
	:	10%	1	1
	:			
11.3.4				
	:		30%	1
	:			

12

12.0.1

12.0.2

12.0.3

:

1

2

()

3

4

5

6

7

8

()

9

10

12.0.4

:

1

2

3

4

5

6

7

8

9

10

11

12

: 10% 1
 5% 10
 :

12.0.5

:

1

2

3

4

5

: 20% 1
 :

13

13.0.1

13.0.2

13.0.3

13.0.4

1

2

3

4

13.0.5

1

2

3

4

5

13.0.6

:

1

2

3

4

13.0.7

:

1

2

3

4

5

5

5

15°

13.0.8

13.0.9

A

A.1

A.1.1

A.1.2

100W

A.1.3

A.1.4

10m

2

100m

16

10m

1

100m

8

A.1.5

A.2

A.2.1

A.2.2

A.2.3

1.2

A.2.4

A.2.5

2.0Pa

A.2.6

:

1

(A.2.6-1)



图 A. 2. 6-1 正压风管式漏风量测试装置

2		0.22	0.7(=d/D)	
		10	5	D
3			2D	
0.3%	2%			
4			1°	
	0.015D			
5				
6		:		

$$Q = 3600\varepsilon \cdot \alpha \cdot A_n \sqrt{\frac{2}{\rho} \Delta P} \tag{A.2.6}$$

Q — (m³/h)

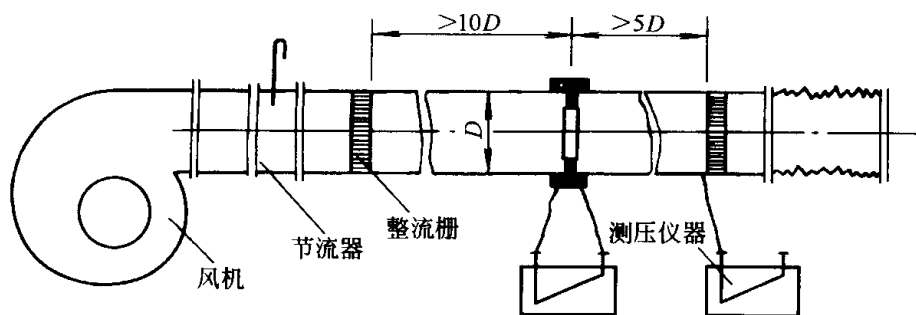
—
—

A_n — (m²)

— (kg/m³)

P — (Pa)

7 A.2.6-2

10⁵ Re 2.0× 10⁶

0.05 ² 0.49

50mm D 1000mm

10⁵



图 A. 2. 6-2 孔板流量系数图

8

A.2.6

表 A.2.6 采用角接取压标准孔板流束膨胀系数 ϵ 值 ($k=1.4$)

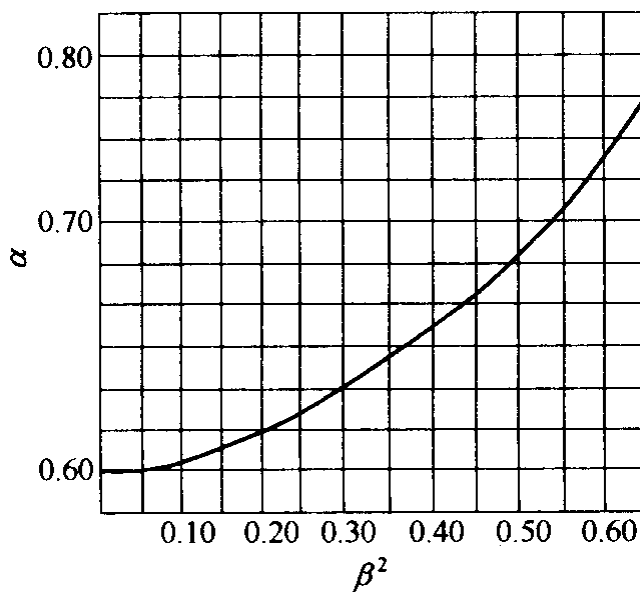
P_2/P_1	1.0	0.98	0.96	0.94	0.92	0.90	0.85	0.80	0.75
0.08	1.0000	0.9930	0.9866	0.9803	0.9742	0.9681	0.9531	0.9381	0.9232
0.1	1.0000	0.9924	0.9854	0.9787	0.9720	0.9654	0.9491	0.9328	0.9166
0.2	1.0000	0.9918	0.9843	0.9770	0.9698	0.9627	0.9450	0.9275	0.9100
0.3	1.0000	0.9912	0.9831	0.9753	0.9676	0.9599	0.9410	0.9222	0.9034

1
2 P_2/P_1

9

A.2.6-3



图 A. 2. 6-3 负压风管式漏风量测试装置

A.2.7

:

1

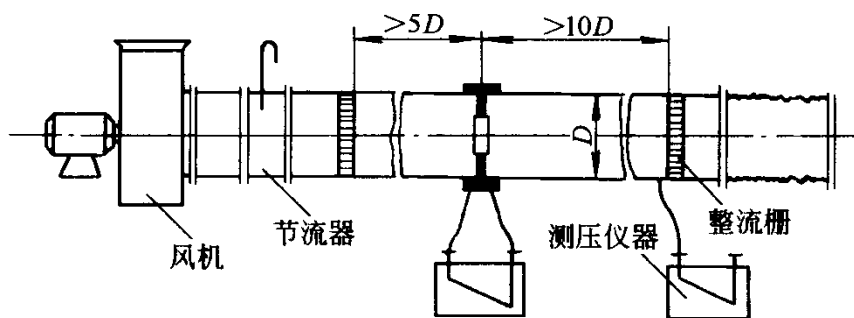
A.2.7-1

2

(A.2.7-2)

A.2.7-1

3

1.5

3

0.75m/s

()

A.2.7-1



D_S —小号喷嘴直径; D_M —中号喷嘴直径; D_L —大号喷嘴直径



图 A. 2. 7-2 标准长颈喷嘴

4

1.5

5 15 35m/s

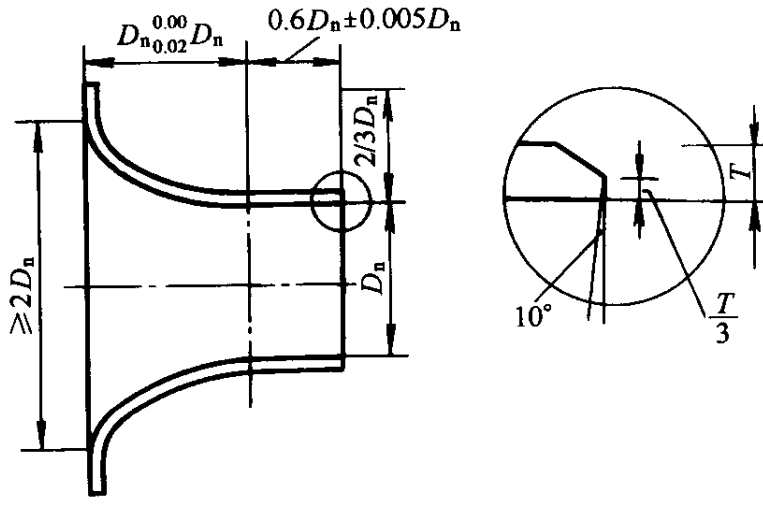
6

7

:

$$Q_n = 3600C_d \cdot A_d \sqrt{\frac{2}{\rho} \Delta P} \tag{A.2.7-1}$$

$$Q = \sum Q_n \tag{A.2.7-2}$$

Q_n — (m³/h)

C_d — (127mm 0.99 127mm A.2.7

A.2.7-3)

A_d — (m²)

P — (Pa)

表 A.2.7 喷嘴流量系数表

Re	C_d	Re	C_d	Re	C_d	Re	C_d
12000	0.950	40000	0.973	80000	0.983	200000	0.991
16000	0.956	50000	0.977	90000	0.984	250000	0.993
20000	0.961	60000	0.979	100000	0.985	300000	0.994
30000	0.969	70000	0.981	150000	0.989	350000	0.994

8

A.2.7-4



图 A. 2. 7-4 负压风室式漏风量测试装置

A.3

A.3.1

A.3.2

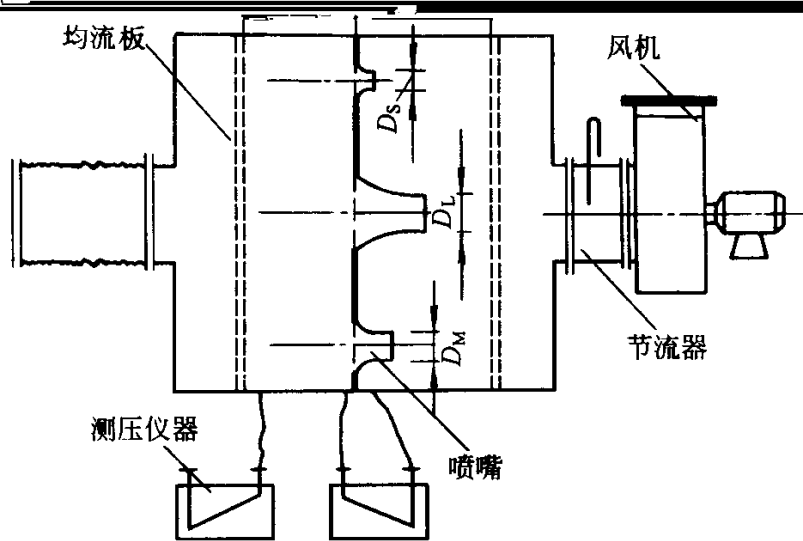
A.3.3

)

(

A.3.4

:

$$Q_0 = Q(P_0 / P)^{0.65} \tag{A.3.4}$$

P_0 — 500Pa

Q_0 — $m^3/(h \cdot m^2)$

P — (Pa)

Q — $m^3/(h \cdot m^2)$

B

B.1

B.1.1

0.3m

0.6m

5

B.1.2

:

1

2

6

2

3

5

200mm

3

4

3

B.2

B.2.1

B.2.2

2.0Pa

B.2.3

0.2m/s

B.3

B.3.1

1L/min

D

B.3.2

表 B.4.4 每次采样的最少采样量 $V_s(L)$ 表

	(μm)					
	0.1	0.2	0.3	0.5	1.0	5.0
1	2000	8400	—	—	—	—
2	200	840	1960	5680	—	—
3	20	84	196	568	2400	—
4	2	8	20	57	240	—
5	2	2	2	6	24	680
6	2	2	2	2	2	68
7	—	—	—	2	2	7
8	—	—	—	2	2	2
9	—	—	—	2	2	2

2 1min 2L

3 () 3

3

4 4

ISO14644—1 F

B.4.5 :

1

2

3

1.5m

4

3

B.4.6 () 2 9

C_i N

95% 9 N

1

C_i

B.4.6-1

表 B.4.6-1 洁净度等级及悬浮粒子浓度限值

	D C _n (pc m ³)					
	0.1μ m	0.2μ m	0.3μ m	0.5μ m	1.0μ m	5.0μ m
1	10	2	—	—	—	—
2	100	24	10	4	—	—
3	1000	237	102	35	8	—
4	10000	2370	1020	352	83	—
5	100000	23700	10200	3520	832	29
6	1000000	237000	102000	35200	8320	293
7	—	—	—	352000	83200	2930
8	—	—	—	3520000	832000	29300
9	—	—	—	35200000	8320000	293000

1	(N)	
2	D(μ m)	(C _n)
	$C_n = 10^N \times (\frac{0.1}{D})^{2.08}$	
3	0.1 5.0μ m	3
	1.5	

2 N 95%

:

$$(N + t \times s / \sqrt{n})$$

N— N= C_i/n

n—

s— N :s= $\sqrt{\frac{(C_i - N)^2}{n - 1}}$

t— i

5 ()

6

7

(

)

8

B.5

B.5.1

(

)

37 48h

B.5.2

90mm

30min

B.5.2

B.5.3

(

)

表 B.5.2

最少培养皿数

5	44
5	14
6	5
7	2

B.5.4

:

1

22± 2

50%± 10%

2

3

4

5

6 100L/min
7 20m/s

B.6

B.6.1

30min

B.6.2

1

2 ()

3

4

0.5m

0.8m

B.6.3

B.6.1

表 B.6.1

温、湿度测点数

	50m ²	20 50m ²
$t \pm 0.5 \pm 2$	5	3 5
$RH = \pm 5 \pm 10\%$		
$t \pm 0.5$	2m	5
$RH \pm 5\%$		

B.6.4

90%

90%

B.7

B.7.1

0.5 1.5m

0.5m

0.5m

B.7.2

B.6.3

B.7.3

B.7.4

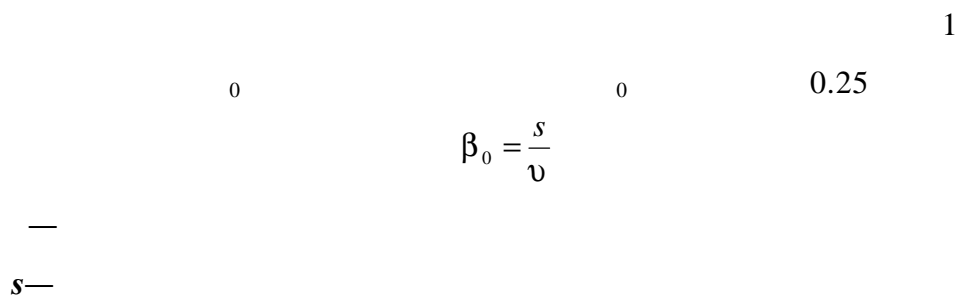

B.8

B.8.1

B.8.2

1.1 1.5m

50m²

C

C.1

C.1.1

()

C.1.2

() C.3.1

C.1.3

() () C.4.1 C.4.2

C.2

C.2.1

C.2.1-1 C.2.1-2

C.2.2

C.2.2

C.2.3

C.2.3-1 C.2.3-2 C.2.3-3

C.2.4

C.2.4

C.2.5

C.2.5-1 C.2.5-2 C.2.5-3

C.2.6

C.2.6

C.2.7

C.2.7-1 C.2.7-2 C.2.7-3

C.2.8

C.2.8-1 C.2.8-2

C.2.9

C.2.9

C.3

C.3.1

C.3.1

C.4

()

C.4.1

:

C.4.1-1

C.4.1-2

C.4.1-3

C.4.1-4

C.4.1-5

C.4.1-6

C.4.1-7

C.4.2

()

C.4.2

表 C.2.1-1

风管与配件制作检验批质量验收记录
(金属风管)

	1				
	4.2.1				
	2				
	4.2.3				
	3				
	4.2.5				
	4				
	4.2.6				
	5				
	4.2.10				
6					
4.2.12					
7					
4.2.13					

续表 C.2.1-1

	1			
	4.3.1-1			
	2			
	4.3.1-2 3			
	3			
	4.3.1-4			
	4			
	4.3.2			
	5			
	4.3.2-4			
6				
4.3.3				
7				
4.3.3				
8				
4.3.4				
9				
4.3.11				

**表 C.2.1-2 风管与配件制作检验批质量验收记录
(非金属、复合材料风管)**

	1				
	4.2.2				
	2				
	4.2.4				
	3				
	4.2.5				
	4				
	4.2.6 4.2.7				
	5				
	4.2.8				
	6				
	4.2.9				
7					
4.2.11					
8					
4.2.12					
9					
4.2.13					

续表 C.2.1-2

	1			
	4.3.1			
	2			
	4.3.5			
	3			
	4.3.6			
	4			
	4.3.7			
	5			
	4.3.8			
6				
4.3.9				
7				
4.3.10				
8				
4.3.11				

表 C.2.2 风管部件与消声器制作检验批质量验收记录

					()			
	1	5.2.1						
	2	5.2.2						
	3	5.2.3						
	4	5.2.4						
	5	5.2.5						
	6	5.2.6						
	7	5.2.7						
	8	5.2.8						

续表 C.2.2

1	5.3.1			
2	5.3.2			
3	5.3.3			
4	5.3.4			
5	5.3.5			
6	5.3.6			
7	5.3.7			
8	5.3.8			
9	5.3.9			
10	5.3.10			
11	5.3.11			
12	5.3.12			

表 C.2.3-1 风管系统安装检验批质量验收记录
(送、排风, 排烟系统)

	1				
	6.2.1				
	2				
	6.2.2				
	3				
	6.2.2-3				
	4				
	80				
	6.2.3				
	5				
6.2.4					
6					
6.2.9					
7					
6.2.8					

续表 C.2.3-1

	1			
	6.3.1			
	2			
	6.3.2			
	3			
	6.3.3			
	4			
	6.3.4			
	5			
	6.3.1-8			
	6			
6.3.5				
7				
6.3.8				
8				
6.3.9				
9				
6.3.10				
10				
6.3.11				

表 C.2.3-2

风管系统安装检验批质量验收记录
(空调系统)

	1				
	6.2.1				
	2				
	6.2.2				
	3				
	6.2.2-3				
	4				
	80				
	6.2.3				
	5				
6.2.4					
6					
6.2.9					
7					
6.2.8					

续表 C.2.3-2

1	6.3.1				
	2	6.3.2			
	3	6.3.3			
	4	6.3.4			
	5	6.3.1-8			
	6	6.3.5			
	7	6.3.6			
	8	6.3.8			
	9	6.3.11			
	10	7.3.20			

表 C.2.3-3

风管系统安装检验批质量验收记录
(净化空调系统)

	1				
	6.2.1				
	2				
	6.2.2				
	3				
	6.2.2-3				
	4				
	80				
	6.2.3				
	5				
6.2.4					
6					
6.2.5					
7					
6.2.6					
8					
6.2.7					
9					
6.2.8					

续表 C.2.3-3

	1			
	6.3.1			
	2			
	6.3.2			
	3			
	6.3.3			
	4			
	6.3.4			
	5			
	6.3.1-8			
	6			
	6.3.5			
7				
6.3.6				
8				
6.3.8				
9				
6.3.12				
10				
6.3.7				
11				
6.3.12				

**表 C.2.5-1 通风与空调设备安装检验批质量验收记录
(通风系统)**

	1				
	7.2.1				
	2				
	7.2.2				
	3				
	7.2.4				
	4				
	7.2.4-3				
	5				
	7.2.7				
6					
7.2.8					
7					
7.2.10					

续表 C.2.5-1

	1			
	7.3.1			
	2			
	7.3.5			
	3			
	7.3.6			
	4			
	7.3.7			
	5			
	7.3.13			
6				
7.3.14				
7				
7.3.18				
8				
7.3.19				

**表 C.2.5-2 通风与空调设备安装检验批质量验收记录
(空调系统)**

	1				
	7.2.1				
	2				
	7.2.2				
	3				
	7.2.3				
	4				
	7.2.7				
5					
7.2.8					
6					
7.2.9					

续表 C.2.5-2

	1	7.3.1		
	2		7.3.2	
	3	7.3.3		
	4	7.3.4		
	5	7.3.13		
	6	7.3.15		
	7	7.3.14		
	8	7.3.19		
	9	7.3.16		
	10	7.3.17		
	11	7.3.18		

表 C.2.5-3 通风与空调设备安装检验批质量验收记录
(净化空调系统)

	1				
	7.2.1				
	2				
	7.2.2				
	3				
	7.2.3				
	4				
	7.2.6				
	5				
7.2.5					
6					
7.2.7					
7					
7.2.8					
8					
7.2.9					

续表 C.2.5-3

	1			
	7.3.1			
	2			
	7.3.2			
	3			
	7.3.8			
	4			
	7.3.9			
	5			
	7.3.10			
6				
7.3.11				
7				
7.3.14				
8				
7.3.12				
9				
7.3.13				
10				
7.3.18				

表 C.2.6 空调制冷系统安装检验批质量验收记录

1	8.2.1-1 3				
2	8.2.1-2				
3	8.2.2				
4	8.2.3				
5	8.2.4				
6	8.2.5				
7	8.2.6				
8	8.2.7				
9	8.2.8				
10	8.2.9				
11	8.2.10				

续表 C.2.6

1	8.3.1-1 2 4 5			
2	8.3.1-3			
3	8.3.2			
4	8.3.3			
5	8.3.4-1 2 3 4			
6	8.3.4-5 6			
7	8.3.5-2 5			
8	8.3.5-1			
9	8.3.6			

**表 C.2.7-1 空调水系统安装检验批质量验收记录
(金属管道)**

	1	9.2.1			
	2	9.2.2-3			
	3	9.2.2-5			
	4	9.2.5			
	5	9.2.2-4			
	6	9.2.4			
	7	9.2.4-3			
	8	9.2.3			
	9	9.2.2-1			

续表 C.2.7-1

1	9.3.2				
	2	9.3.3			
	3	9.3.4			
	4	9.3.5			
	5	9.3.6			
	6	9.3.6			
	7	9.3.8			
	8	9.3.10			
	9	9.3.10-4			

表 C.2.7-2 空调水系统安装检验批质量验收记录
(非金属管道)

	1	9.2.1			
	2	9.2.2-3			
	3	9.2.2-5			
	4	9.2.5			
	5	9.2.2-4			
	6	9.2.4			
	7	9.2.4-3			
	8	9.2.3			
	9	9.2.2-1			

续表 C.2.7-2

	1PVC-U 9.3.1			
	2PP—R 9.3.1			
	3PEX 9.3.1			
	4 9.3.9			
	5 9.3.8			
	6 9.3.10			
	7 9.3.10-4			
	:			

表 C.2.7-3 空调水系统安装检验批质量验收记录
(设备)

	1	9.2.1			
	2	9.2.6			
	3	9.2.7			
	4	9.2.8			
	1	9.3.7			
	2	9.3.11			
	3	9.3.12			
	4	9.3.13			
	5	9.3.10-3			

**表 C.2.8-1 防腐与绝热施工检验批质量验收记录
(风管系统)**

	1				
	10.2.1				
	2				
	10.2.2				
	3	2m			
	10.2.3				
	4				
10.2.4					
5					
10.2.5					

续表 C.2.8-1

1	10.3.1				
	2	10.3.2 10.3.3			
	3	10.3.4			
	4	10.3.5			
	5	10.3.6			
	6	10.3.7			
	7	10.3.8			
	8	10.3.12			

表 C.2.8-2

防腐与绝热施工验批质量验收记录
(管道系统)

	1				
	10.2.1				
	2				
	10.2.2				
	3	2m			
	10.2.3				
	4				
	10.2.4				
5					
10.2.5					

续表 C.2.8-2

	1	10.3.1			
	2	10.3.2 10.3.3			
	3	10.3.4			
	4	10.3.7			
	5	10.3.8			
	6	10.3.9			
	7	10.3.10			
	8	10.3.11			
	9	10.3.12			
	10	10.3.13			

表 C.2.9 工程系统调试检验批质量验收记录

	1						
	11.2.2-1						
	2						
	11.2.2-2						
	3						
	11.2.2-3						
	4						
	11.2.2-4						
	5						
	11.2.2-5						
	6						
11.2.3-1							
7							
11.2.3-2							
8							
11.2.3-3							
9							
11.2.4							
10							
11.2.5							

续表 C.2.9

1	11.3.1-2 3				
	2	11.3.1-1			
	3	11.3.2-2			
	4	11.3.3-1 3			
	5	11.3.3-2			
	6	11.3.3-4 5 6			
	7	11.3.3			
	8	11.3.4			

**表 C.4.1-1 通风与空调子分部工程质量验收记录
(送、排风系统)**

1					
2					
3					
4					
5					
6					
7					

表 C.4.1-5

通风与空调子分部工程质量验收记录
(净化空调系统)

1					
2					
3					
4					
5					
6					
7					
8					
9					
10					

表 C.4.2 通风与空调分部工程质量验收记录

1					
2					
3					
4					
5					
6					
7					

1 :

1) :

" " " "

2) :

" " " " " "

3) :

" " " "

" "

2 " "

" "